

ELECTRONIC HOMESTYLE

COMMERCIAL FRONT CONTROL FRONT LOAD WASHER

Built for Reliable Performance

Engineered and built like no other, the Speed Queen front load washer is designed to be everything people thought a washer couldn't be, beginning with its revolutionary suspension and sensing technology. This groundbreaking innovation manages and redistributes out-of-balance loads to deliver uninterrupted cycles, virtually eliminate vibration and operate so quietly neighboring residents won't even know it's running. It also touts an incredible 440 G-Force extraction speed to maximize moisture removal, reduce dry times and minimize utility costs. And as if that's not game-changing enough, this smooth-running, laundry-optimizing machine delivers increased water efficiency for the ultimate user experience. It's everything you never knew it could be. Front load products have met every design standard to be 100% ADA compliant.

- Revolutionary balancing technology
- Industry leading 1200 RPM spin speed exerts 440 G-force extraction
- Extra-wide 15.5" door opening and 180° door swing
- Rugged suspension system
- Easy-to-read digital display
- Durable stainless steel tub
- Four-compartment soap dispenser



ENERGY STAR® Certified



Electronic homestyle control is designed for durability and easy operation with attractive selection buttons and cycle status indicator lights.

SPECIFICATIONS

COMMERCIAL FRONT CONTROL FRONT LOAD WASHER

MODEL - see below for all models and activation available	
CONTROL OPTION	Electronic Homestyle
COLOR	White
CAPACITY - lb (kg)	9.5 (21.5)
OVERALL WIDTH - in (mm)	26.875 (683)
OVERALL DEPTH - in (mm)	27.73 (704)
OVERALL HEIGHT - in (mm)	40.42 (1027)
CYLINDER VOLUME - cu. ft. (liters)	3.42 (96.8)
SPIN SPEED G-FORCE (RPM)	440 (1200)
MOTOR SIZE - HP (kw)	0.9 (0.67)
WATER CONSUMPTION PER CYCLE - g (liter)	11.7 (44.3)
WF (WATER FACTOR) - gal/ft ³ (liters/liter/cycle)	3.7 (0.50)
MEF (Modified Energy Factor) ft ³ /kWh/cycle (Liters/kWh/cycle)	2.38 (82.29)
AVAILABLE WATER TEMPERATURES	Hot, Warm, Cold
AVAILABLE CYCLES	Heavy Duty, Normal Eco, Perm Press, Delicate, Rinse & Spin, Spin
ELECTRICAL REQUIREMENTS (v/Hz/Ph-Amp)	120/60/1 - 15 Amp
WATER PRESSURE - p.s.i. (bar)	20-120 (1.4/8.3)
DRAIN	Pump
CYLINDER FINISH	Stainless Steel
NET WEIGHT - kg (lb)	260 (118.3)
SHIPPING WEIGHT - kg (lb)	270 (122.5)
SHIPPING DIMENSIONS APPROX. - mm (in)	Width 34 (864)
	Depth 30 (762)
	Height 44.5 (1130)
AGENCY APPROVALS	cULus

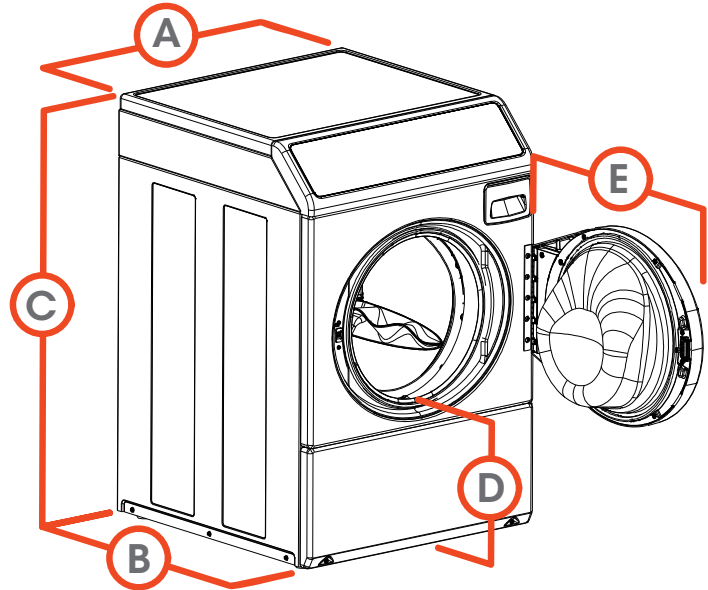

A. OVERALL WIDTH - in (mm)	26.875 (683)
B. OVERALL DEPTH - in (mm)	27.73 (704)
C. OVERALL HEIGHT - in (mm)	40.42 (1027)
D. FLOOR TO DOOR OPENING - in (mm)	14.6 in. (371)
E. DOOR SWING - in (mm)	24.06 in. (611)

MODELS	ACTIVATION
LFNE5BSP113TW01	
LFNE5BJP113TW01+	

+ Supply Injection

**2018 Model Number:
LFNE5BSP115TW01
(same Washer)
No Supply Injection**

For the most accurate information, the installation guide should be used for all design and construction purposes. Due to continuous product improvements, design and specifications subject to change without notice. The quality management system of Alliance Laundry Systems' Ripon facility has been registered to ISO 9001:2008.