

SPEED QUEEN MULTI-HOUSING

MANUAL HOMESTYLE

COMMERCIAL REAR CONTROL SINGLE DRYER

Built for Reliable Performance

Speed Queen's manual control single load dryer combines heavy-duty construction with reliable operation proven to stand the test of time. They're designed with less moving parts for one reason: so you'll face fewer maintenance problems and less wear and tear down the road. Our cabinet design maintains the perfect balance of heat, airflow and tumble action for optimal performance and efficiency. The equipment provides an advantage on such issues as energy conservation, equipment breakdowns and vandalism. Customers have the flexibility to choose from four heat/cycle selections.

- Industry's largest door opening 2.06 sq. ft. (1914 cm²)
- Door is reversible for installation flexibility
- High efficiency exhaust blower with superior airflow 220 cfm (105 liters/sec)
- 100% serviceable from the front
- Space-saving narrow cabinet 26-7/8" (683 mm)
- Upfront lint filter easy to clean and secured
- Durable galvanized steel cylinder
- Efficient and fast dry cycle
- Extra-large capacity

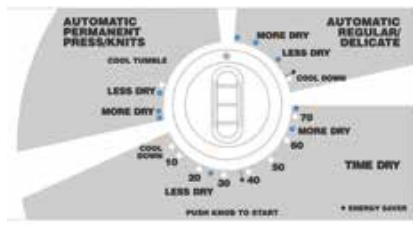

Manual homestyle control offers a reliable heavy-duty multi-cycle timer knob.

SPECIFICATIONS

COMMERCIAL REAR CONTROL SINGLE DRYER

MODEL - see below for all models and activation available	
CONTROL OPTION	Manual Homestyle
COLOR	White
CAPACITY - lb (kg)	18 (8.2)
OVERALL WIDTH - in (mm)	26.875 (683)
OVERALL DEPTH - in (mm)	28 (711)
OVERALL HEIGHT - in (mm)	43 (1092)
CYLINDER VOLUME - cu. ft. (liters)	7.0 (198)
MOTOR (CAPACITOR START AND THERMAL PROTECTED)	.33 HP
TYPE OF GAS (GAS MODELS ONLY)	Factory equipped natural/mixed gas
AIR OUTLET DIAMETER - in (mm)	4 (102)
EXHAUST AIRFLOW - cfm (liters/sec)	220 (105)
AVAILABLE CYCLES	Permanent Press/Knits, Regular/Delicate, Time Dry
ELECTRICAL REQUIREMENTS	Electric 120/240/60/1-30 amp 120/208/240/60/1-30 amp
	Gas 120/60/1-15 amp
HEATING ELEMENT	Electric 5350W, 240V 4750W, 208V
	Gas 25,000 Btu
NET WEIGHT - lb (kg)	Electric 136 (61.7)
	Gas 136 (61.7)
SHIPPING WEIGHT lb (kg)	Electric 126 (57.2)
	Gas 126 (57.2)
SHIPPING DIMENSIONS APPROX. - in (mm)	Width 30.5 (775)
	Depth 29.5 (762)
	Height 45 (1143)
AGENCY APPROVALS	Electric cULus
	Gas cCSAus

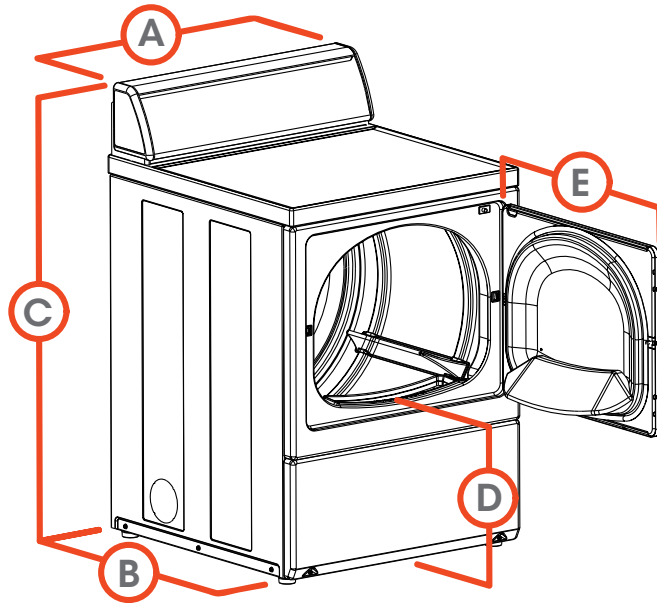

A. OVERALL WIDTH - in (mm)	26.875 (683)
B. OVERALL DEPTH - in (mm)	28 (711)
C. OVERALL HEIGHT - in (mm)	43 (1092)
D. FLOOR TO DOOR OPENING -in (mm)	15.44 (392)
E. DOOR SWING - in (mm)	23.5 (597)

MODELS	VOLTAGE/FREQ/PH	
LDE30RGS173TW01	120/240/60/1	Electric
LDG30RGS113TW01	120/60/1	Gas

■ Electric dryers come equipped for 240/60/1 operation. They can be field converted to operate on 208/60/1 with optional 61928 conversion kit. Gas dryers can be field converted for operation on LP gas with optional 458P3 conversion kit.

For the most accurate information, the installation guide should be used for all design and construction purposes. Due to continuous product improvements, design and specifications subject to change without notice. The quality management system of Alliance Laundry Systems' Ripon facility has been registered to ISO 9001:2008.