



OWNER'S MANUAL
MANUEL DU PROPRIÉTAIRE
MANUAL DEL PROPIETARIO



DEHUMIDIFIER Owner's Manual.....	1 - 9
DÉSHUMIDIFICATEUR Manuel du propriétaire.....	10 - 18
DESHUMIDIFICADOR Manual del propietario.....	19 - 27

MODEL • MODÈLE • MODELO DDR050BLPBDB

Welcome

Welcome to the Danby family. We are proud of our quality products and we believe in dependable service. We suggest that you read this owner's manual before plugging in your new appliance as it contains important operation information, safety information, troubleshooting and maintenance tips to ensure the reliability and longevity of your appliance.

Visit www.Danby.com to access self service tools, FAQs and much more. For additional assistance call **1-800-263-2629**.

Note the information below; you will need this information to obtain service under warranty.

You must provide the original purchase receipt to validate your warranty and receive service.

Model Number: _____

Serial Number: _____

Date of Purchase: _____

Need Help?

Before you call for service, here are a few things you can do to help us serve you better.

Read this owner's manual:

It contains instructions to help you use and maintain your appliance properly.

If you receive a damaged appliance:

Immediately contact the retailer or builder that sold you the appliance.

Save time and money:

Check the troubleshooting section at the end of this manual before calling. This section will help you solve common problems that may occur.



1-800-26- Danby
(1-800-263-2629)



Important Safety Information

READ AND FOLLOW ALL SAFETY INSTRUCTIONS

SAFETY REQUIREMENTS

This appliance is not intended for use by persons (including children) whose physical, sensory or mental capabilities may be different or reduced, or who lack experience or knowledge, unless such persons receive supervision or training to operate the appliance by a person responsible for their safety.

Children should be supervised to ensure that they do not play with the appliance.

To avoid risk of electric shock, do not operate this dehumidifier in an area that is likely to accumulate standing water. If this condition develops, disconnect the power supply before stepping into the water.

Do not store or use combustible materials such as gasoline or other flammable vapors or liquids in the vicinity of this or any other appliance.

Do not insert fingers or other objects into grills or openings in the appliance.

Do not cover or block the intake and exhaust openings.

Do not operate the appliance without the filter installed.

Do not operate the appliance near heat sources.

This appliance is intended for indoor, residential applications only. Do not use this dehumidifier outdoors. Do not use this dehumidifier for commercial or industrial applications.

GROUNDING INSTRUCTIONS

This appliance must be grounded. Grounding reduces the risk of electrical shock by providing an escape wire for the electrical current.

This appliance has a cord that has a grounding wire with a 3-prong plug. The power cord must be plugged into an outlet that is properly grounded. If the outlet is a 2-prong wall outlet, it must be replaced with a properly grounded 3-prong wall outlet. The serial rating plate indicates the voltage and frequency the appliance is designed for.

WARNING - Improper use of the grounding plug can result in a risk of electric shock. Consult a qualified electrician or service agent if the grounding instructions are not completely understood, or if doubt exists as to whether the appliance is properly grounded.

Do not connect the appliance to extension cords, adapters or together with another appliance in the same wall outlet.

Do not splice the power cord. Do not under any circumstances cut or remove the third ground prong from the power cord.

If the power supply cord is damaged, it must be replaced by the manufacturer, its service agent or similar qualified person in order to avoid hazard.

SAVE THESE INSTRUCTIONS!

OPERATING INSTRUCTIONS

OPERATION

- Place the dehumidifier on a smooth, level floor that is strong enough to support the appliance with a full bucket of water.
- Do not place the dehumidifier on carpeting as this can block air flow around the appliance.
- Do not force casters to move over carpeting as the appliance can become unbalanced and spill water.
- To maintain efficiency, operate the appliance in an enclosed area. Keep nearby doors and windows closed.
- Maintain a minimum clearance of 20 cm (8 inches) on the sides and back of the appliance and 40 cm (16 inches) on the top and front of the appliance to allow for proper air circulation.
- The recommended ambient operating temperature is between 5°C (41°F) and 32°C (90°F).
- Any time the appliance is placed on its back or side, it must be allowed to stand upright for 6 hours before plugging in to avoid damage to internal components.
- The default humidity setting is 40% and high fan speed. Depending on humidity conditions the dehumidifier may not start automatically under the default setting. This means the humidity in the surrounding air is less than 40%. Press the down button to lower the set humidity until the set humidity is lower than the ambient humidity.
- For optimal performance, ensure that the humidity setting is 10% lower than the ambient humidity. It is normal for the ambient humidity to vary up to 5% above or below the set humidity.
- It is recommended in normal conditions to set the humidity between 40-45%.
- It is normal for the dehumidifier to exhaust warm air from the top.

FEATURES

1. Control panel
2. Handles (both sides)
3. Water bucket
4. Water level indicator
5. Air intake
6. Air filter
7. Continuous drain outlet
8. Power cord storage band
9. Power cord
10. Pump drain outlet

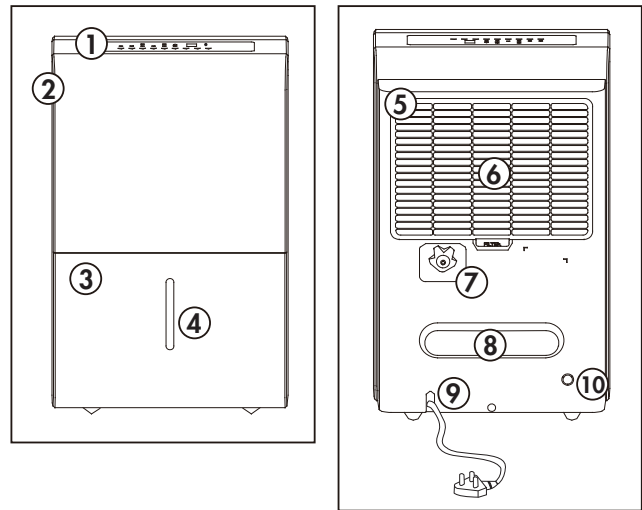

CASTER INSTALLATION

1. Remove the casters from the bucket of the dehumidifier.
2. Locate the arrow on the bottom of the dehumidifier and insert the caster according to the arrow direction.
3. Slide the caster in as far as it will go, until it snaps into place.

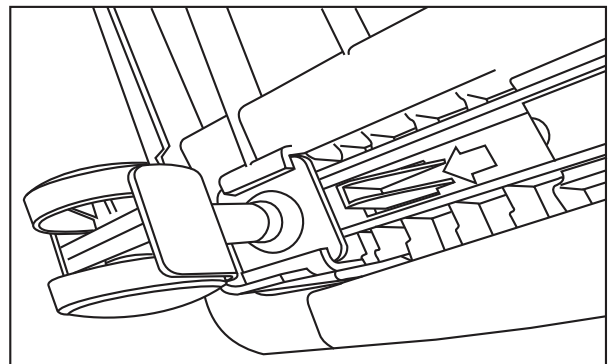

OPERATING INSTRUCTIONS

CONTROL PANEL

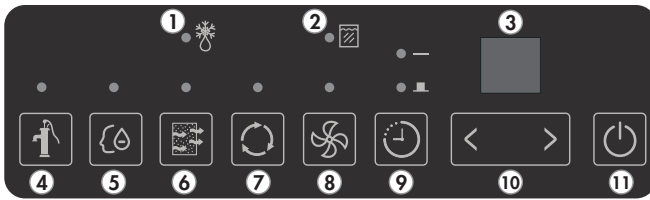

- 1. Auto-defrost:** When frost builds on the evaporator coils, the compressor will cycle off and the fan will continue to run until the frost disappears.
- 2. Bucket Full Light:** The light will illuminate when the bucket is full or incorrectly positioned inside the cabinet. The compressor and fan operation are terminated as a safety feature. When the bucket is emptied or correctly re-positioned the dehumidifier will resume operation automatically.
- 3. Display:** Shows the actual ($\pm 5\%$ accuracy) room humidity level in a range of 30% RH to 90% RH. Otherwise, displays selection when programming humidity or timer.
- 4. Drain Pump Button:** Connect the provided drain hose and press this button to activate the drain pump. The pump light will illuminate.
- 5. Smart Dehumidify:** This function will automatically adjust the humidity level with the fluctuating room temperatures. The humidity level cannot be adjusted in this setting, it will stabilize between 45% - 55%.
- 6. Filter Button:** The check filter light will illuminate after 250 hours of operation as a reminder to clean the filter. To reset this function after cleaning the filter, press the filter button and the light will go off.
- 7. Continuous Button:** Press to activate the continuous dehumidifying operation.
- 8. Fan button:** Controls the fan speed. Press to select either high or normal fan speed. The light will illuminate on high fan speed.
- 9. Timer Button:** Press to initiate the auto-start and auto-stop feature. Set a start or stop time from 0.0 to 24 hours using the (\triangleright) and (\triangleleft) keys.
- 10. (\triangleleft / \triangleright) Buttons:** The humidity level can be set within a range of 35% to 85% relative humidity in 5% increments. For drier air, press the (\triangleleft) button and set to a lower percentage value. For more damp air, press the (\triangleright) button and set a higher percentage value.
- 11. Power Button:** Press to turn the dehumidifier on or off.

TIMER FUNCTION

Auto Off Function

1. When the appliance is turned on, press the timer button to activate the auto-stop timer. The auto-stop light will illuminate.
2. Press the up and down buttons to change the set time in 0.5 hour increments up to 10 hours and then in 1 hour increments up to 24 hours.
3. Press the timer button to confirm programming.

Auto On Function

4. When the appliance is turned off, press the timer button to activate the auto-start timer. Set the time as per the instructions above. Press the timer button again to confirm programming.

The auto on and auto off functions can be used at the same time by first setting one and then the other. Both indicator lights will illuminate and the display will count down to the appliance either turning off or on, whichever function was set first.

Note: The timer will not cycle the appliance on and off indefinitely. The auto on and auto off timers will function one time and then the appliance will return to regular functioning.

Turning the appliance on or off at any time or changing the timer setting to 0.0 will cancel the timer settings.

MEMORY AND AUTO RESTART SETTINGS

Each time the appliance is disconnected or reconnected or in the event of a power failure, the appliance will default to the last program setting that was used.

If the appliance shuts off unexpectedly due to a power failure, it will restart with the previous settings automatically once power resumes.

OPERATING INSTRUCTIONS

WATER REMOVAL

There are two ways to remove collected water from the appliance.

1. Water Bucket

The dehumidifier will automatically collect condensed water in the water bucket. When the bucket is full or displaced inside the unit, the float actuator inside the bucket breaks contact with the safety switch. The compressor will shut down, preventing moisture from being condensed. The fan will continue to run for approximately 2-3 minutes. Water may drip onto the base of the appliance and onto the floor. Make sure to protect flooring when emptying the water bucket.

Never tamper with or attempt to defeat the water level float system. Proper installation of the water bucket is crucial in maintaining reliable operation.

To empty the bucket, gently remove it from the appliance by gripping both sides and pulling outward. Be cautious when removing the bucket, it will be full and can be heavy.

Do not place the water bucket directly on the floor. The bottom of the bucket is uneven and it will fall over and spill water.

Empty the bucket and replace it in the appliance. The dehumidifier will not function without the bucket installed.

The bucket should be cleaned every few weeks to prevent mold growth. Only use mild detergent to clean the bucket; do not use harsh chemicals or bleach.

2. Continuous Drain

Water can be removed from the appliance using the continuous drain and a standard garden hose (not provided).

Before using any automatic drain functions, check that all drain ports are clean and free of debris. There are either one or two drain ports inside the bucket compartment of the appliance, remove the bucket to see them. There are one or two drain ports on the back of the appliance where the drain hoses attach. All drain ports should be cleaned with a pipe cleaner prior to use.

Note: Do not clean the drain ports with anything more rigid than a pipe cleaner as this can damage the appliance.

Note: If the drain ports are clogged or dirty it can cause water to leak from the bottom of the appliance.

Remove the cover from the continuous drain outlet and attach the female threaded end of the garden hose to the back of the appliance. Direct the other end of the garden hose to a bucket or floor drain.

Ensure that the garden hose is not bent and goes straight down from the back of the appliance. The continuous drain is only activated by gravity so any bends or upward motion in the hose will stop the water from draining.

The garden hose should be cut so that it is no more than 1.8 m (6 feet) long. If the drain hose is too long water may not drain completely which can lead to stagnant water and mildew build up inside the hose.

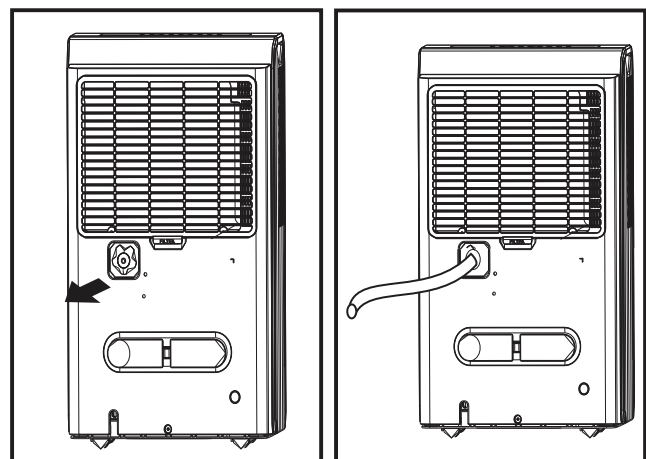

OPERATING INSTRUCTIONS

3. Pump Drain

In situations where the drain hose cannot reach a floor drain or if the drain hose needs to reach a receptacle that is above the level of the appliance, water can be drained from the appliance using the pump.

1. Remove the cap on the pump drain port on the back of the appliance.
2. Connect the provided drain hose to the drain port.
3. Ensure that there are no bends in the drain hose.
4. Press the pump button to initiate the pump drain.
5. The maximum length of the pump drain hose is 5 m (16 feet).

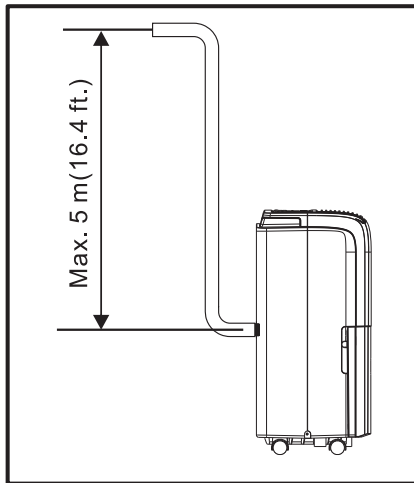
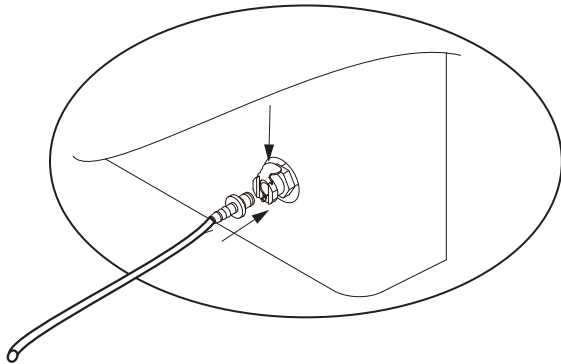

INTERNAL PUMP ARM

Inside the appliance there is a pump arm that will draw water out of the bucket and then drain it out through the drain hose. When replacing the bucket in the appliance after emptying it, ensure that the pump arm has not fallen down or the bucket will not go back into the appliance.

If the pump arm has fallen down, gently push it up toward the top of the unit until it clicks into place.

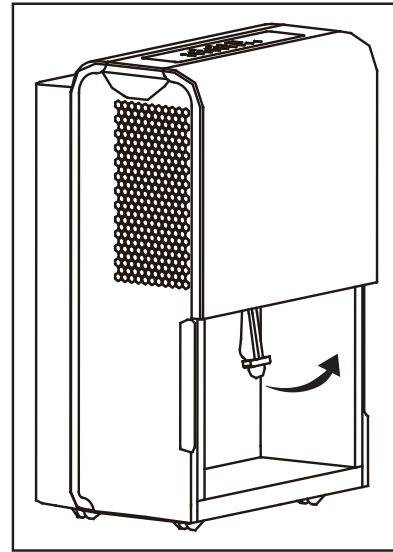

Note: The pump will only become active once the bucket is full of water.

As the dehumidifier removes water from the air, the water will first fill the bucket. When the bucket is full, the pump arm will drop into the bucket and remove as much water as it can reach. The water will drain through the attached drain hose.

The appliance will continue to function, removing more water from the air and filling the bucket again.

CARE & MAINTENANCE

AIR FILTER

The filter indicator will illuminate after 250 hours of use, indicating that the filter should be cleaned.

Remove the filter from the back of the appliance. Use a vacuum to remove dust from the filter or wash with warm water and mild detergent. Ensure the filter is completely dry before replacing it in the appliance. Press the filter button to reset the filter indicator.

Note: Do not operate the appliance without the air filter installed.

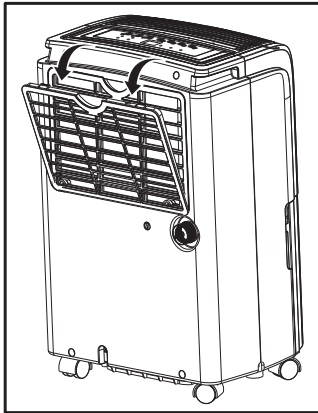

LONG TERM STORAGE

Ensure that the inside of the appliance is dry before storing for the off season to help avoid the growth of mold or mildew. Ensure the filter is clean and dry. Secure the power cord with the power cord strap as per the image below. Store the appliance upright and covered in a dry location.

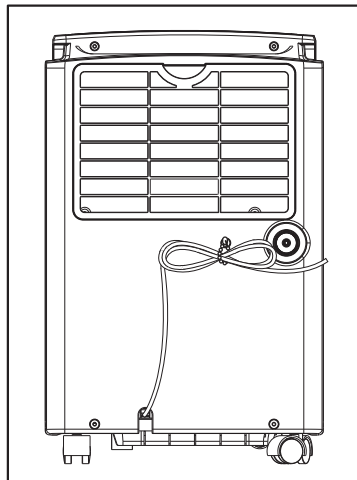
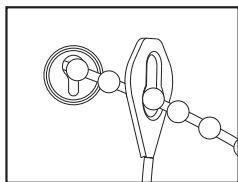
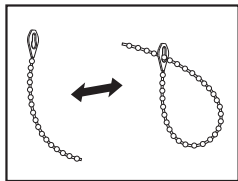

CLEANING

To avoid possible electric shock, ensure that the appliance is unplugged before performing any cleaning or maintenance.

The outside of the appliance can be wiped clean with a soft cloth or with a lukewarm, damp cloth if necessary.

Do not use gasoline, benzene, thinner or any other chemicals to clean this appliance as these substances can cause damage to the finish and deformation of plastic parts.

Never pour water directly onto the appliance as this will cause deterioration of electrical components and wiring insulation.

Ensure that the drain ports on the interior of the appliance and the drain ports on the back of the appliance are free of dirt and calcium build up.

ERROR CODES

If the display panel shows any of the below error codes, unplug the appliance, let it stand for 5-10 minutes and then plug it back in. If the error persists, call for service.

AS - Humidity sensor error

ES - Temperature sensor error

E3 - Control panel error

P2 or **Eb** - Bucket is full or not in the correct position

DISPOSAL

This appliance may not be treated as regular household waste, it should be taken to the appropriate waste collection point for recycling of electrical components. Check for local regulatory compliance regarding approved and safe disposal of this appliance.

TROUBLESHOOTING

Danby Consumer Care: 1-800-263-2629

Hours of operation:

Monday to Thursday 8:30 am - 6:00 pm Eastern Standard Time
 Friday 8:30 am - 4:00 pm Eastern Standard Time

Information in this manual is subject to change without notice.

PROBLEM	POSSIBLE CAUSE
Appliance will not operate	<ul style="list-style-type: none"> • Plug is not fully inserted into the wall outlet • Blown fuse or circuit breaker • Ambient humidity is lower than the set humidity • Bucket is full or is not in the proper position
Insufficient dehumidifying	<ul style="list-style-type: none"> • Air filter is dirty • Blocked air flow • Appliance size is too small for application • Ambient humidity is lower than the set humidity
Noise	<ul style="list-style-type: none"> • Air filter is dirty • Bucket is not in proper position • Floor surface is not level
Odors	<ul style="list-style-type: none"> • Formation of mold or mildew on internal wet surfaces • Place an algacide tablet in the water bucket
Water on floor	<ul style="list-style-type: none"> • Hose connection is loose • Drain cover has been removed
Frost build up	<ul style="list-style-type: none"> • When ambient temperature is below 5°C (41°F) frost may form • Switch the appliance to fan only mode until the frost melts