



SPEED QUEEN® MULTI-HOUSING LAUNDRY SOLUTIONS
Stacked Washer-Dryer

Electronic Control

Built for Reliable Performance

Speed Queen's stacked washer-dryer brings an innovative stacked concept that takes up half the floor space that a conventional washer and dryer does when situated side by side. The freestanding softmount design can be installed on all floor types or levels. Both washer and dryer have the same hookups and connections as a standard washer and dryer. No additional plumbing or electrical change is needed. Speed Queen's stacked washer-dryer combines heavy-duty construction with reliable operation proven to stand the test of time. They're designed with less moving parts for one reason: so you'll face fewer maintenance problems and less wear and tear down the road. Front load products have met every design standard to be 100% ADA compliant.

Washer (ADA Compliant)

- Rugged suspension system
- Industry leading 1200 RPM spin speed exerts 440 G-force extraction
- Durable stainless steel washtub
- Four-compartment soap dispenser
- Extra-wide 15.5" door opening and 180° door swing
- Stainless-steel braided fill hoses are 48" long with Garden Hose Thread (GHT). Screens included.

Dryer

- Upfront lint filter easy to clean and secured
- Industry's largest door opening 2.06 sq. ft. (1914 cm²)
- Quiet, efficient blower system



Washer Control

Dryer Control

Electronic Control

Electronic control is designed for durability and easy operation with attractive selection buttons and cycle status indicator lights.

Stacked Washer-Dryer

Electronic Control

Specifications		
Control Option		Electronic
Color		White
Capacity - lb (kg)	Washer	21.5 (9.5)
	Dryer	18 (8.2)
Cylinder Volume - cu. ft. (liters)	Washer	3.42 (96.8)
	Dryer	7.0 (198)
Motor Size - HP (kw)		0.9 (0.67)
Type Of Gas (Gas Models Only)		Factory equipped natural/mixed gas
Water Consumption Per Cycle g (liter)		13.68 (51.8)
IWF (Water Factor) gal/ft ³ (liters/liter/cycle)		4.0 (0.53)
MEF ₂ (Modified Energy Factor) ft ³ /kWh/cycle (Liters/kWh/cycle)		2.20 (62.3)
Available Water Temperatures		Hot, Warm, Cold
Available Cycles	Washer	Heavy Duty, Normal Eco, Perm Press, Delicate, Rinse and Spin
	Dryer	Regular, Perm Press, Delicate, Time Dry, Quick Dry, Fluff Up
Air Outlet Diameter - mm (in)		4 (102)
Exhaust Airflow - cfm (liters/sec)		220 (105)
Electrical Requirements	Electric	120/240/60/1-30 amp 120/208/240/60/1-30 amp
	Gas	120/60/1-15 amp
Heating Element	Electric	5350W, 240V 4750W, 208V
	Gas	25,000 Btu
Net Weight - lb (kg)		350 (158.8)
Shipping Weight - lb (kg)		380 (172.4)
Shipping Dimensions Approx. - in (mm)	Width	34 (864)
	Depth	30 (762)
	Height	80 (2032)
Agency Approvals	Electric	cULus
	Gas	cCSAus

Models	Voltage/Freq/PH	
LTEE5ASP179TW01	208-240/60/1	Electric
LTGE5ASP119TW01	120/60/1	Gas

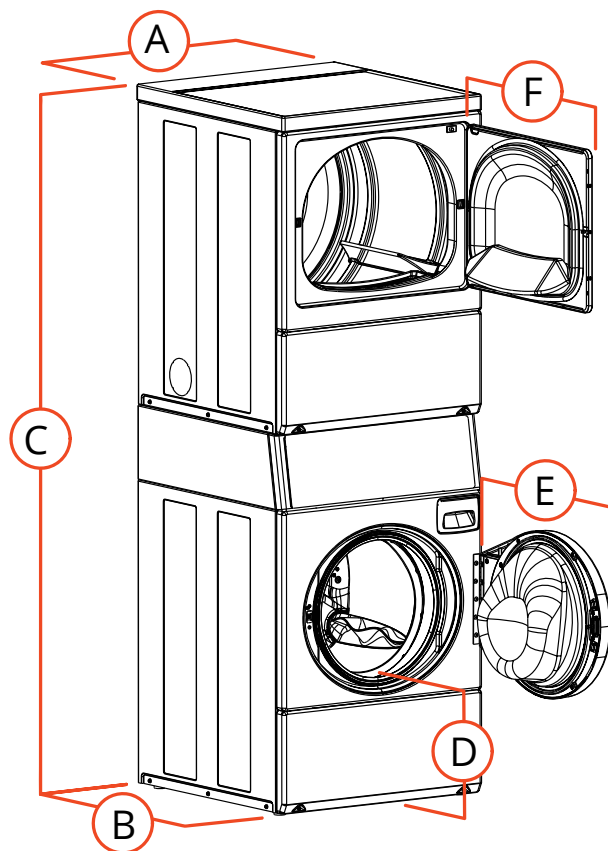

A. Overall Width - in (mm)	26.875 (683)
B. Overall Depth - in (mm)	27.73 (704)
C. Overall Height - in (mm)	78.17 (1986)
D. Floor To Door Opening -in (mm)	14.5 (368)*
E. Door Swing - in (mm)	24 (610)

* For ADA compliance turn legs out from base 0.5 inches

NOTE: Stacked washer-dryer requires two power cords. One for washer, one for dryer.

For the most accurate information, the installation guide should be used for all design and construction purposes. Due to continuous product improvements, design and specifications subject to change without notice. The quality management systems at Alliance Laundry Systems are registered to ISO 9001.

Commercial product is not authorized for sale to Residential end consumers.