



- CFM REDUCTION
- DIM LIGHT
- AMBIENT LIGHT
- LED LIGHT
- SEMI BAFFLE FILTER
- TOUCH CONTROL

ELICA'S EXCLUSIVE PLUS FEATURES

With a compact 4 ¾" height, Aria is an ideal choice where under-cabinet space is limited. Its upgraded 430 CFM internal blower provides sufficient ventilating power for most kitchens. Aria also offers the luxury and convenience of LED dimmable lighting with 2 Baffle Slot filters and glass touch controls.

Available in 30" or 36" width, Aria is designed for standard ducted installation and can also be used as a recirculating system using the kit available as an accessory.

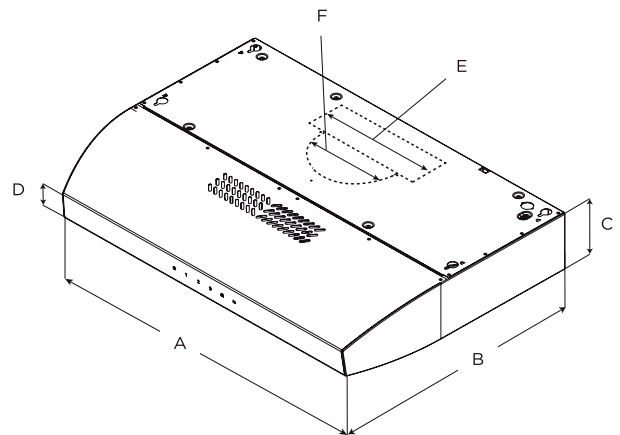

- ≥24"
- ≥30"

MOUNTING HEIGHT RANGE

	Models	
	EA1430SS	EA1436SS
A	30" (76.2 cm)	36" (91.4 cm)
B	20" (50.8 cm)	
C	4 7/10" (12 cm)	
D	2" (5.2 cm)	
E	3 1/4" x 10" (8.3 cm x 25.4 cm)	
F	7" (17.8 cm)	

SPECIFICATIONS



	30" UNIT	36" UNIT
Model:	EAI430SS	EAI436SS
Dimensions:	30" W x 20" D x 4 7/10" H	36" W x 20" D x 4 7/10" H
Blower Type(internal):	400 CFM, 3-Speed Internal+ Boost	
Blower Performance:		
Speed 1*	150 CFM	
Speed 2*	240 CFM	
Speed 3*	280 CFM	
Boost	430 CFM	
Noise (sones):* Working Speed	Min: 1.2, Max: 5.5	*HVI Certified values
Finish:	Stainless Steel with Black Glass	
Controls:	Touch Control 3S+ Booster	
Illumination:	2 Premium LED Dimmable Lights, 2.5 W	
Filter Type:	2 Dishwasher-Safe, Stainless Steel Baffle Slot Filters	
Installation Type:	Ducted or Recirculating Installation (Recirculating Kit Sold Separately)	
Duct Transition:	3 1/4" x 10" with Back Draft Damper (top or rear), or 7" Round (top) sold separately	
Electrical:	120V – 60 Hz, 445 Watts at 3.6 Amps	
KITS:		
Optional Recirculating Kit	KIT02178	KIT02179
Optional Stainless Steel Mesh Grease Filter	KIT02591	KIT02592
Optional Backdraft Damper, 7" Round	KIT02723	
CONSUMABLE PARTS:		
Replacement Grease Filter (1)	GF04BA	GF04BB
Replacement Carbon Filter (1)	TM01FA	TM01FB
Replacement Light Bulb (1)	2006BH	

*Consumable parts are sold in units of one (1). Order accordingly

*The product images shown are for illustration purposes only and may not be an exact representation of the product.

PLUS FEATURES



CFM REDUCTION - CFM Reduction System (CRS), is an exclusive feature to Elica hoods, which enables the user to reduce directly in the glass touch control the maximum blower CFM, to meet local code requirements.



DIM-LIGHT - The Dimmer allows you to adjust the brightness of the light as you wish. With Elica, lighting is customized in a discreet, personal and practical way, in order to contribute in creating the perfect kitchen atmosphere.



AMBIENT LIGHT - Elica studies on hood lighting leaves no stone unturned. Here we have thought about products not only able to light the cooktop, but the entire kitchen space. And so the hood is transformed: from a kitchen appliance to a true lighting element. Considering the design of Elica hoods, it is not hard to imagine how this option is quite unique, and represents one extraordinary point of strength for us.



LED LIGHT - LED lighting is undoubtedly the smartest solution in terms of energy saving. Expected life time of over 20.000 hours, represents the most remarkable advantage of LED light bulbs.



STAINLESS STEEL BAFFLE SLOT FILTERS - A baffle shaped stainless steel filter with mesh backing allows air to pass but blocks grease, which drops into the high capacity baffle cavities. The design delivers large volume capacity, excellent capture efficiency at ALL blower speeds, silent operation, plus, durability that will last the life of the hood.



ELECTRONIC TOUCH CONTROLS - Enjoy the modern design and convenience of multi-function electronic touch controls, which are discreetly hidden behind sleek black glass, and will illuminate a soft blue when activated.