

TECHNE SERIES
PALERMO

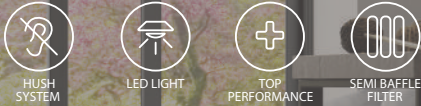

ELICA'S EXCLUSIVE PLUS FEATURES

Palermo provides professional grade performance, while it's 28 1/4" width and 10 3/4" depth enables it to be discreetly installed within standard 12" deep cabinetry, making it ideal for smaller kitchens or where the range hood needs to be out of sight. Palermo has a powerful 600 CFM blower to support most cooking needs. Stylish stainless steel push button controls operate a 3-speed blower and LED lighting.

Easy maintenance, higher efficiency and a cleaner kitchen are ensured by Elica's Baffle Slot Filters, which capture a higher percentage of grease and hold larger volumes of grease than traditional baffle filters. Palermo is designed for standard ducted or recirculating installation.

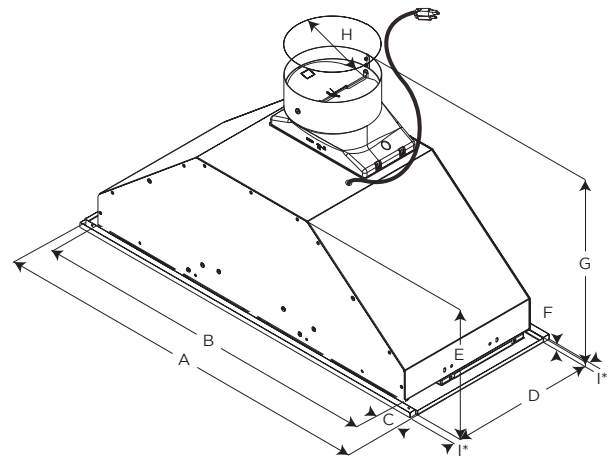

Model

EPR628S1

A	28 ¹⁷ / ₆₄ " (71.8 cm)
B	26" (66 cm)
C	1 ⁹ / ₆₄ " (2.9 cm)
D	10 ³ / ₄ " (27.3 cm)
E	9 ⁷ / ₃₂ " (24.2 cm)
F	0 ² / ₆₄ " (.85 cm)
G	14 ⁹ / ₁₆ " (37 cm)
H	6" (15.2 cm)
I*	1/2" (127 cm)



MOUNTING
HEIGHT
RANGE

SPECIFICATIONS

	28" UNIT
Model: Dimensions: Blower Type(internal): Blower Performance: Speed 1 Speed 2 Speed 3 Noise (sones): Working Speed Finish: Controls: Illumination: Filter Type: Installation Type: Duct Transition: Electrical:	EPR628S1 28 1/4"W x 10 3/4"D x 14 9/16" H 600 CFM, 3-Speed Internal 190 CFM 350 CFM 600 CFM Min: 2.1, Max: 6 Sones Stainless Steel Stainless Steel Push Button 2 Premium LED, 2.5 Watts 2 Dishwasher-Safe, Stainless Steel Baffle Slot Ducted or Recirculating Installation (Recirculating Kit Sold Separately) 6" Round with Back Draft Damper (top) 120V-60Hz, 455 Watts at 3.8 Amps
KITS: Optional Recirculating Kit with 2 Carbon Filters Optional 30" Hood Liner 29" W x 17 1/2" - 20 1/2"D x 4"H Optional 36" Hood Liner 35" W x 17 1/2" - 20 1/2"D x 4"H	KIT02770 KIT02773 KIT02774
CONSUMABLE PARTS: Replacement Grease Filter (1) Replacement Carbon Filter (1)	GRI0018064 FB016A
WARRANTY:	2 YEARS PARTS AND LABOR, EARN A 3RD YEAR OF FULL FACTORY WARRANTY REGISTERING YOUR PRODUCT ON ELICA.COM

** For valid warranty extension, register within 3 months from purchase. For USA & Canada Users only

*The product images shown are for illustration purposes only and may not be an exact representation of the product.

PLUS FEATURES



HUSH SYSTEM - An exclusive sound deadening technology that effectively reduces sound levels up to 35%, compared to typical range hoods.



LED LIGHT - LED lighting is undoubtedly the smartest solution in terms of energy saving. Expected life time of over 20,000 hours, represents the most remarkable advantage of LED light bulbs.



TOP PERFORMANCE - Excellent performance for models equipped with this plus. High fume capturing capacity with an average aspiration range of 600 CFM's. with low noise levels, 1.2 - 1.7 sones at working speed.



STAINLESS STEEL BAFFLE SLOT FILTERS - A baffle shaped stainless steel filter with mesh backing allows air to pass but blocks grease, which drops into the high capacity baffle cavities. The design delivers large volume capacity, excellent capture efficiency at ALL blower speeds, silent operation, plus, durability that will last the life of the hood.