

# Café™ ENERGY STAR® 27.6 Cu. Ft. 4- Door French-Door Refrigerator

CVE28DP4NW2 / CVE28DP2NS1 / CVE28DP3ND1

# CAFÉ

DISTINCT BY DESIGN™



CVE28DP4NW2  
Matte White with  
Brushed Bronze handles

ALSO  
AVAILABLE IN



CVE28DP2NS1  
Stainless Steel  
with Brushed  
Stainless handles



CVE28DP3ND1  
Matte Black  
with Brushed  
Stainless handles



## FEATURES & BENEFITS

Enjoy the flexibility of a **Convertible Drawer with Soft Freeze** with settings as low as 23 degrees or as high as 42 degrees, and keep items organized with sliding glass dividers

Relish the bright, uniform light of an **LED light wall** that spans the back wall of the refrigerator, illuminating the fresh food section so every item is easy to find

Effortlessly fill containers with filtered water by simply pressing the **AutoFill** button which uses sensors to dispense the perfect amount every time

Keep your produce fresh thanks to a **Humidity Control System with two bins**—a sealed Wet Zone that maintains high humidity for fruits and vegetables and a vented Dry Zone for produce that prefer a dryer environment

Easily pull out a slim, **full-width tray** to accommodate gourmet pizzas and other frozen, uniquely shaped items

From produce to packaged goods, keep any food fresh with **TwinChill™ evaporators** that create separate climates in the fresh food and freezer sections

Receive alerts on your smart device whenever your refrigerator's internal temperature dips below normal, thanks to **built-in WiFi connectivity** that helps you keep foods party-platter ready

Spend more time filling and less time fumbling thanks to the **Next Gen Dispenser**, which senses your proximity and automatically illuminates, so you never have to compromise on function and fashion

## APPEARANCE

Exterior design	Bowed flat top
Handle	Café™
Handle design	Café Pro
Hidden door hinge(s)	Yes

## FEATURES

Configuration	French-door & Double drawer
WiFi connect	Built-in
Connected capabilities	Amazon Alexa; The Google Assistant; IFTTT
Temperature management features	Turbo Cool setting; Multiflow air system
Temperature management system	TwinChill™ evaporators
Defrost type	Frost Guard
Control type	Electronic temperature controls
Dispenser	Large stainless steel; Cubes, crushed ice and chilled water
Dispenser features	Hands-free AutoFill; Door alarm; LED dispenser light; Water filter indicator light
Icemaker	Space saving ice
Water filtration	GE water filtration 6 month; XWF; Water filter indicator light
Filter location	Left wall
Fresh food cabinet drawers	3 total; 2 adjustable humidity drawers; 1 full-width, adjustable temperature drawer; Electronic temperature control w/ colored LED lighting
Fresh food cabinet shelves	4 glass split; 1 Quick Space shelf
Fresh food door bins	6 total; 2 with gallon storage; 1 adjustable
Fresh food door features	Dairy compartment; Drop down tray
Fresh food features	Showcase LED lighting (7); Deli pan
Freezer door bins	3 (2 adjustable tilt-out)
Freezer storage baskets	2 full-width
Freezer features	Interior lighting - Showcase LED (2); Turbo Freeze; Freezer drawer with full-extension slides
Exterior style	Free-standing
Leveling system	2 point front adjustable
Performance features	Easily removable door gaskets; Sabbath Mode capable
Center drawer features	Convertible drawer; 6 temperature settings (Soft Freeze, Meats, Beverages, Snacks, Wine, Lock); 2 Tuck Away glass dividers; Full-extension slides

## CAPACITY

Total capacity (cubic feet)	27.6 cu. ft.
Fresh food capacity	15.47 cu. ft.
Freezer capacity	8.44 cu. ft.
Convertible drawer capacity	3.65 cu. ft.

## WEIGHTS & DIMENSIONS

Overall depth	36-3/4 in.
Overall height	69-7/8 in.
Overall width	35-5/8 in.
Case depth without door	29 in.
Depth with door open 90°	48-3/8 in.
Depth without handle	34-1/4 in.
Height to top of hinge	69-3/4 in.
Height to top of case	68-5/8 in.
Width w/door open 90 degrees incl. handle	44-7/8 in.
Back air clearances	2 in.
Side air clearances	1/8 in.
Top air clearances	1 in.
Approximate shipping weight	425 lb.
Net weight	390 lb.

# Café™ ENERGY STAR® 27.6 Cu. Ft. 4- Door French-Door Refrigerator

CVE28DP4NW2 / CVE28DP2NS1 / CVE28DP3ND1

# CAFÉ

DISTINCT BY DESIGN™

## WARRANTY

Parts warranty	Limited 1-year entire appliance; Limited 5-year sealed refrigerating system
Labor warranty	Limited 1-year entire appliance; Limited 5-year sealed refrigerating system
Warranty notes	See written warranty for full details

## DIMENSIONS

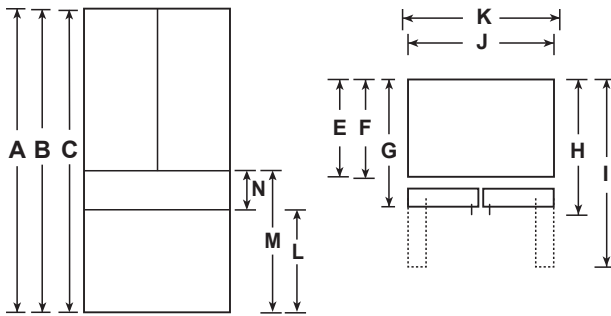

Overall Dimensions	
A - Overall Height to top of door (in)	69 7/8
B - Height to top of hinge cover (in)	69 3/4
C - Height to top of case (in)	68 5/8
D - Hinge Cover Depth from Case Flange (in)	6
E - Case Depth without door (in)	29
F - Case Depth without door including protrusions (in)	29 3/4
G - Case Depth without Door Handle (in)	34 1/4
H - Overall Case Depth with Door Handle (in)	36 3/4
I - Depth with FF Door open 90 deg (in)	48 3/8
J - Case Width (in)	35 5/8
K - Width with door open 90 deg including handle (in)	44 7/8
L - Top endcap of FZ drawer to floor (in)	24 1/2
M - Top endcap of Middle drawer to floor (in)	33 1/2
N - End cap to End cap height of middle drawer (in)	8 5/8
O - Top Endcap of Freezer Doors to Floor (in)	NA

## ADDITIONAL ACCESSORIES



CXQB4H4PNBZ  
Brushed Bronze  
4 handles  
(Standard on Matte White)



CXQB4H4PNSS  
Brushed Stainless  
4 handles  
(Standard on Matte Black and Stainless Steel)



CXQB4H4PNBT  
Brushed Black  
4 handles



CXQB4H4PNCU  
Brushed Copper  
4 handles