

# FRONT LOAD WASHER

4.3 Cu. Ft.

EFLW317TIW

With LuxCare™ Wash and IQ-Touch™ Controls



## PRODUCT DIMENSIONS

Height	38"
Width	27"
Depth	32"

## MORE EASY-TO-USE FEATURES

### 5 CYCLES TO CARE FOR EVERY FABRIC

Clean all your special items with tailored cycles for delicates, heavy duty, and more.

### FITS MORE ROOMS

With a standard 27" platform, our products are designed to fit just about anywhere you want to put them.

### SPACIOUS CAPACITY

Easily cleans a king-sized comforter with spacious 4.3 cu. ft. drum.

Available in:



Island White  
(IW)

\*As tested on conventional wood floor construction with vinyl floor covering.

## SIGNATURE FEATURES



### THOROUGH CLEANING WITH THE LUXCARE™ WASH SYSTEM

Our LuxCare™ Wash System offers a thorough clean with improved wash actions, temperature control, and smart load sensing.



### ENERGY STAR® CERTIFIED

Electrolux washers meet strict criteria to guarantee high-quality energy efficient performance — without sacrificing clean.



### 10-YEAR MOTOR WARRANTY PLUS LIFETIME TUB WARRANTY

Rest easy knowing your washer is backed by a 10-year motor and lifetime tub warranty.



### PERFECT BALANCE® SYSTEM & SECOND FLOOR GUARANTEE

Balances loads for smooth, quiet operation. So quiet\* you can even run your washer on the second floor or near bedrooms without noticing it.

# FRONT LOAD WASHER

EFLW317TIW



## 27" FRONT LOAD WASHER

Capacity D.O.E.	4.3 Cu.Ft.
-----------------	------------

### FEATURES

Pull-to-Open Door	Yes
iQ-Touch™ Controls	Yes
Perfect Steam™ Wash System	
Balance System	Perfect Balance®
Sound System	Luxury-Quiet™
Lighting	
Pull-to-Open Dispenser Drawer	Yes
Wash System	LuxCare™
Integral Water Heater	
Wash Drum	Stainless Steel
Automatic Temperature Control	Yes
Automatic Water Level Adjustment	Yes
Auto Prewash Detergent Dispenser (Liquid/Powder)	
Auto Bleach Dispenser (Liquid Only)	Yes
Auto Detergent Dispenser (Liquid/Powder)	Yes
Auto Fabric Softener Dispenser (Liquid Only)	Yes
Tumble Speed (RPM)	Variable
Spin Speed (RPM)	1,100
Reversible Door	
Adjustable Leveling Legs	Yes
ENERGY STAR®	Yes
NSF® Certified	

### CYCLES

Heavy Duty, Normal, Delicates, Rinse & Spin, Clean Washer	5
---	---

### OPTIONS

Wash/Rinse Temperature Combinations	4
Temperature Selections	3
Add Steam	
Spin Speed Selections	3
Soil Level Selections	3
Delay Start	Yes
End-of-Cycle Chime	On/Off

### INSTALLATION OPTIONS

Freestanding, Under Counter*, Stacked (Under Dryer), Pedestal, Hidden (In Closet), Second Floor	Yes
---	-----

### ACCESSORIES

Luxury-Glide® Pedestal with Spacious Storage Drawer – Island White – PN# EPWD157SIW	Optional
Dryer Stacking Kit – PN# STACKIT7X	Optional
Drain Hose Extension Kit – PN# 137098000	Optional

### SPECIFICATIONS

Color –	
Island White	IW
Power Supply Location	Top Right Rear
Water Inlet Location	Top Left Rear
Voltage Rating	120V/60 Hz
Connected Load (kW Rating) @ 120 Volts <sup>†</sup>	1.2
Watts @ 120 Volts	1,200
Amps @ 120 Volts	12
Shipping Weight (Approx.)	247 Lbs.

\*Side-by-Side units in under-counter installation require custom-built countertop and/or cabinetry.

<sup>†</sup>An electrical supply with grounded three-prong receptacle is required. The power supply circuit must be installed in accordance with current edition of National Electrical Code (NFPA 70) and local codes & ordinances.

NOTE: Always consult local and national electric and plumbing codes. Refer to Product Installation Guide for detailed installation instructions on the web at [electroluxappliances.com](http://electroluxappliances.com).

Specifications subject to change.

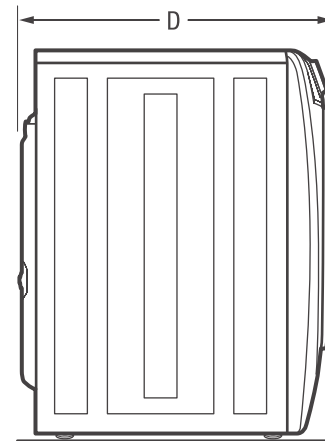
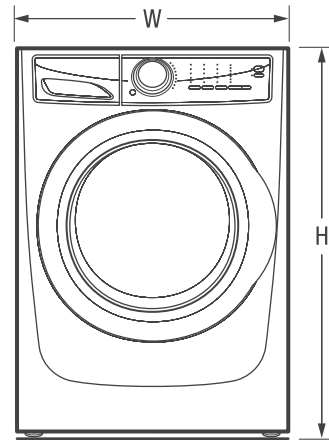

### PRODUCT DIMENSIONS

Height (without 15" Pedestal)	38"
(with 15" Pedestal)	53-1/4"
Width	27"
Depth (to Center of Arc Not Including Hose)	32"
(with Door 90° Open)	53-1/2"

## Electrolux Major Appliances, N.A.

USA • 10200 David Taylor Drive • Charlotte, NC 28262 • 1-877-4electrolux (1-877-435-3287) • [electroluxappliances.com](http://electroluxappliances.com)  
 CANADA • 5855 Terry Fox Way • Mississauga, ON L5V 3E4 • 1-800-265-8352 • [electroluxappliances.ca](http://electroluxappliances.ca)

EFLW317T 02/17

© 2017 Electrolux Home Products, Inc.



High standards of quality at Electrolux Home Products, Inc. mean we are constantly working to improve our products. We reserve the right to change specifications or discontinue models without notice.

# FRONT LOAD WASHER

EFLW317TIW

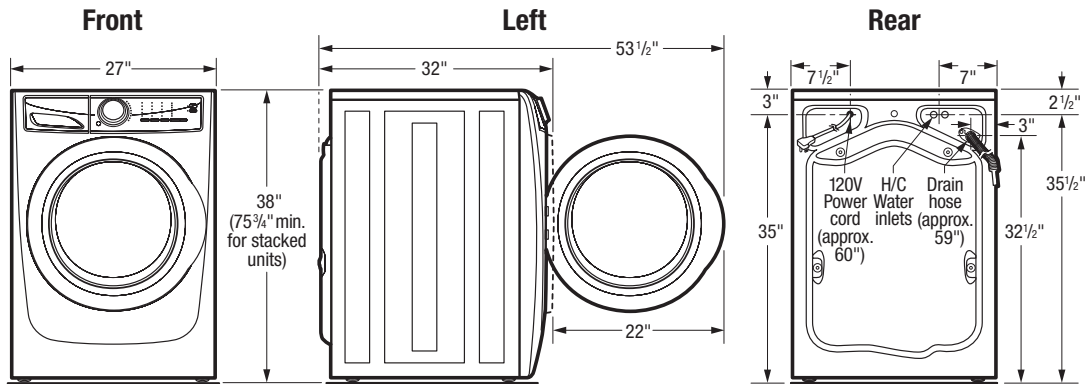

## 15" Pedestal Drawer Installation

Elevates washer height to 53 1/4". For detailed pedestal installation, refer to instructions included with pedestal or on web. Pedestal Installation may require modified utility hookup locations. For details, refer to Product Installation Guide on web.

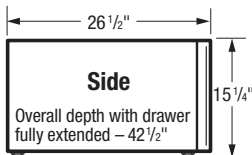
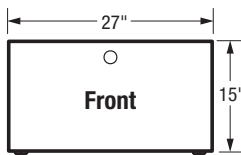

## Built-In Installations

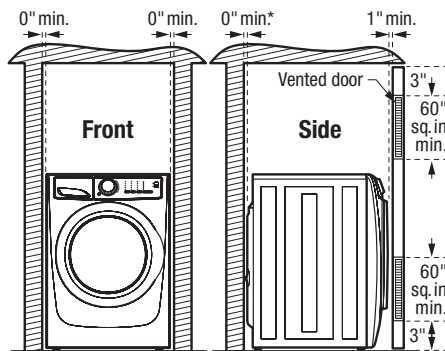

\*Installation with steam dryer requires additional 3/4" hose clearance.

### Closet Installation:

If washer and dryer are installed in same closet, door(s) MUST be vented with 120 sq. in. minimum louvered opening, equally divided, located 3" from top and bottom of door. Louvered door(s) with equivalent air openings for full-length of door is acceptable. Air openings MUST remain unobstructed with door(s) installed.

### Installation Clearances:

Washer can be built in alone or with dryer (*side by side or stacked*) in closet, recess or under counter installation with 0" minimum clearance required around sides and back of unit(s). To achieve 0" minimum rear clearance when installed with dryer, dryer MUST be vented straight back or with quick-turn 90° elbow. Steam dryer requires additional 3/4" steam hose clearance at back of unit(s). Installation of closet door(s) requires additional 1" minimum clearance between front of unit(s) and door(s). Location of plumbing, exhaust and utility hookups MUST be considered when planning any built-in installation. For additional installation details, refer to Product Installation Guides on web.

### Under Counter Installation:

Installation of washer alone or side by side with dryer under counter, requires custom-built countertop and/or cabinetry to accommodate unit(s) height.

### Stacking Units:

Stacking dryer above washer requires use of optional Stacking Kit (PN# STACKIT7X) with modified utility hookup locations for dryer. For complete installation details, refer to instructions included with Stacking Kit or on web.

## Front Load Washer Specifications

- Product Weight – 237 Lbs. / Shipping Weight – 247 Lbs.
- An electrical supply with grounded three-prong receptacle is required. The power supply circuit must be installed in accordance with current edition of National Electrical Code (ANSI/NFPA 70) and local codes & ordinances. (*Do not use same circuit as dryer.*)
- Voltage Rating – 120V/60Hz
- Connected Load (kW Rating) @ 120 Volts = 1.2 kW
- Amps @ 120V = 12A
- Equipped with 120V 3-wire power supply cord, approx. 60" long.
- Always consult local and national electric & plumbing codes.
- To maximize detergent effectiveness, ambient temperature should never be below 60°F.
- Can be installed alone, with or without optional 15" pedestal drawer, or stacked beneath matching Electrolux Dryer, which requires installation of optional dryer stacking kit. (*For installation details, refer to instructions included with optional pedestal or stacking kit or on web.*)
- Can be built in alone or with matching Electrolux Dryer (*side by side or stacked*) in closet, recess or under counter installation with 0" minimum clearance required around sides and back of unit(s). To achieve 0" minimum rear clearance when installed with dryer, dryer MUST be vented straight back or with quick-turn 90° elbow. Steam dryer requires additional 3/4" steam hose clearance at back of unit(s). Installation of closet door(s) requires additional 1" minimum clearance between front of unit(s) and door(s). Location of plumbing, exhaust and utility hookups MUST be considered when planning any built-in installation.
- Under-counter installation requires custom-built countertop and/or cabinetry to accommodate unit(s) height.

- Do NOT install in area exposed to dripping water or outdoor weather conditions, or where gasoline or other flammables, including automobiles, are kept or stored.
- For garage installation, washer MUST be located minimum 18" above floor.
- Floor MUST be solid with 1" maximum slope. To ensure vibration or movement does not occur, reinforcement of floor may be necessary. Do NOT install on carpeted surface.
- Leveling legs supplied to level washer properly and reduce excessive noise and vibration.
- H/C water faucets MUST be installed within 42" of washer's water inlet and MUST be 3/4" garden hose type, to connect to 48-1/2" inlet hoses.
- Water pressure MUST be between 30 and 120 psi with NOT more than 10 psi pressure difference between hot and cold.
- Drain required with standpipe diameter of 1-1/4" min. and height of 24" min./ 96" max. above floor, capable of eliminating 17 gallons per minute. Attached 59" drain hose can reach 79"-high standpipe.

**Note:** For planning purposes only. Refer to Product Installation Guide on the web at [electroluxappliances.com](http://electroluxappliances.com) for detailed instructions.

## Optional Accessories

- Pedestal Drawers – Island White (PN# EPWD157SIW).
- Dryer Stacking Kit – (PN# STACKIT7X).
- Drain Hose Extension Kit – (PN# 137098000).

## Electrolux Major Appliances, N.A.

USA • 10200 David Taylor Drive • Charlotte, NC 28262 • 1-877-4electrolux (1-877-435-3287) • [electroluxappliances.com](http://electroluxappliances.com)  
 CANADA • 5855 Terry Fox Way • Mississauga, ON L5V 3E4 • 1-800-265-8352 • [electroluxappliances.ca](http://electroluxappliances.ca)

EFLW317T 02/17

© 2017 Electrolux Home Products, Inc.



High standards of quality at Electrolux Home Products, Inc. mean we are constantly working to improve our products. We reserve the right to change specifications or discontinue models without notice.